

APPLICATION:

PRODUCT NAME:
BACK-FLOW PREVENTOR

JOB NAME:

SPECIAL CONFIGURATION
 CHECK BASE MODEL AND OPTIONS

QUANTITY:

ITEM NO.

MODEL:
 2542

OPTIONS OR MODIFICATIONS:
 SUPPLY LINES (24" OR 36") CIRCLE LENGTH
 ADD-ON FAUCET (6", 8", 10", 12", 14", 16") CIRCLE
 IN-LINE DUAL CHECK VALVE
 HANDLES (CROSS OR WRIST) CIRCLE STYLE
 VANDAL RESISTANT KIT
 OTHER _____

FEATURES:

* ATMOSPHERIC VENT
* FOR IN-LINE CONTINUOUS PRESSURE APPLICATIONS
* FOR EXPOSED SERVICEABLE INSTALLATIONS
* DOUBLE CHECK DESIGN

SYSTEM LIMITS
* TEMP: 40°F MIN. TO 140°F MAX.
* PRESSURE 200 PSI MAX. STATIC

SHIPPING WEIGHT
* 1.0 LBS

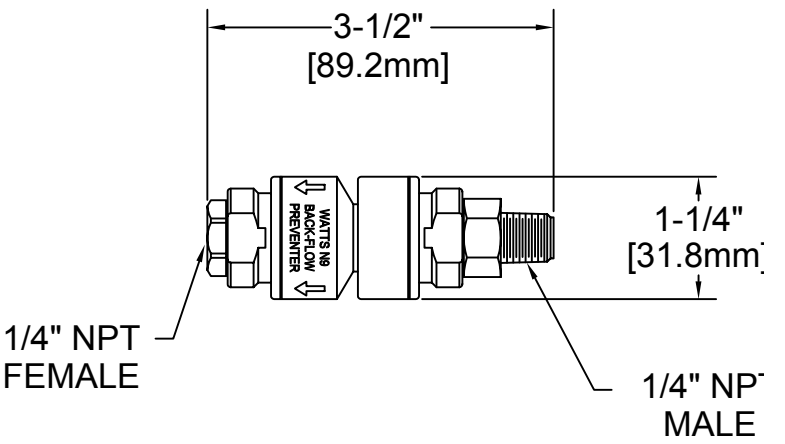

FISHER
 FISHER MANUFACTURING COMPANY
 TOLL FREE: 800-421-6162 - FAX: 800-832-8238
 information@fisher-mfa.com - www.fisher-mfa.com